

INTRODUCTION

Fast, easy breadboarding of circuits using the PA240CX are possible with the EK34 PC board. Mounting holes are provided and the provision for standard banana jacks simplifies connection and testing. The amplifier may be mounted horizontally or vertically. Components are labeled on both sides of the board for ease in probing.

A multitude of circuit configurations are possible, so only several component locations have specific functions and will usually be necessary. This kit is not suitable for use with PA240CC.

PARTS LIST

Part #	Description	Quantity
Eval 34	Evaluation Board PA40/140CX	1
Clamp04	Clamp for HS29	2
MS11	Pin Receptacle, 30 pin strip	1
TW14	Thermal Washer TO220 10/Pack	1
HS29	Heat Sink, 2.7 DEG/W	1

TYPICAL COMPONENT FUNCTIONS

COMPONENT	FUNCTION
C1,7	Alone is a roll off, with R3, 13 is a current out stability network (ref. AN19)
C2,6	With R6, 15 forms noise gain compensation network (ref. AN25)
C3,4	Supply bypass, .22 to 1μF ceramic
C5,8	With R9, 20 forms a Howland stability network, can jumper both to ground +IN
Cc	Sets compensation to match desired gain
Cs	Normally not used.
D1-4	Flyback protection diodes
R1,11	Inverting inputs, install to input line or to ground
R2,12	Negative feedback, install to V for voltage out or to I for current output (ref. AN19)
R3,13	With C1, 7 forms a stability network for current output (ref. AN19)
R4,14	Current sense for current outputs (ref. AN13)
R5,15	With C2, 6 forms noise gain compensation network (ref. AN25)

EQUIVALENT SCHEMATIC

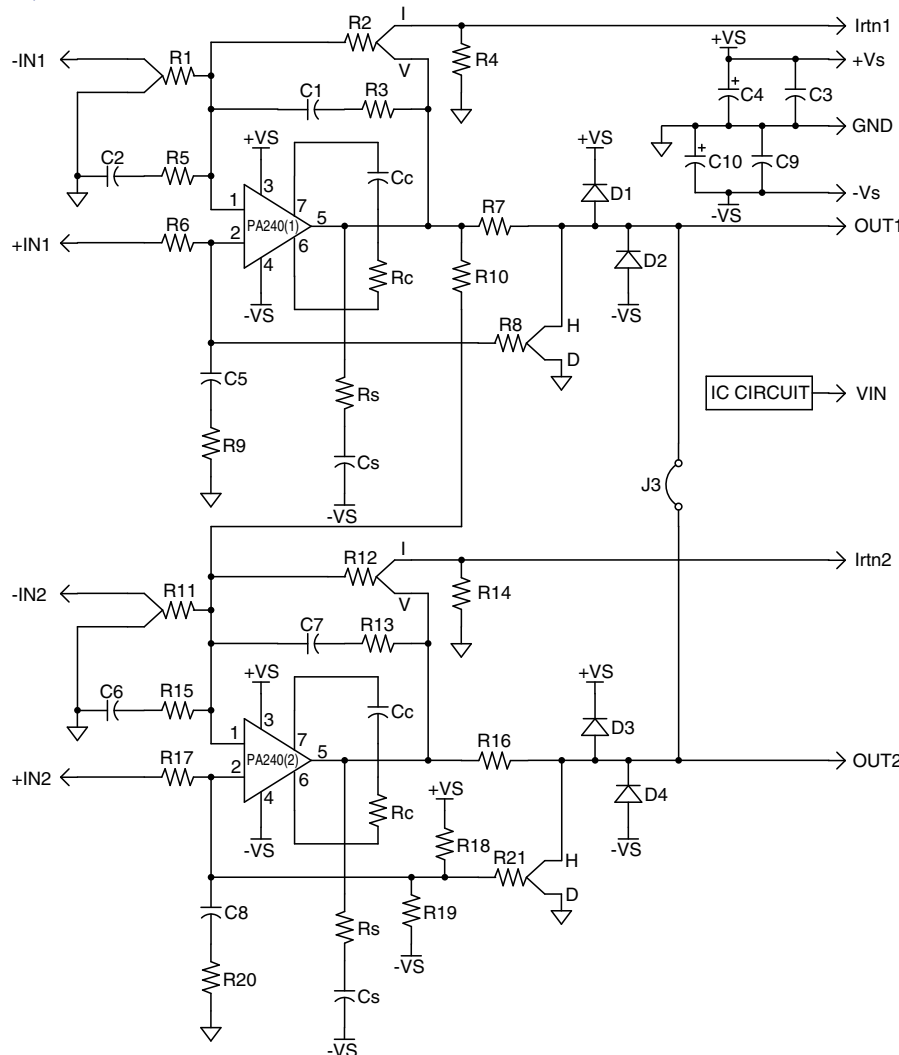

R6,17	Input R for Howland current pump or differential, usually shorted for non-inverting
R7,19	Current sense for Howland current pump. Could also be used to isolate large loads (ref. AN25)
R8,21	Positive feedback, install to H for a Howland current pump, to D for a differential circuit
R9,20	With C5, 8 forms a Howland stability network, can jumper both to ground +IN
R10	With an equal value R12 provides gain = -1 for a bridge slave (ref. AN3,20)
R18,19	Can provide mid-supply reference for single supply bridge (ref. AN3, 20)
Rc	Normally shorted.
Rs	Normally not used.

EK34

EVALUATION KIT
FOR PA240CX PIN-OUT

FIGURE 1.

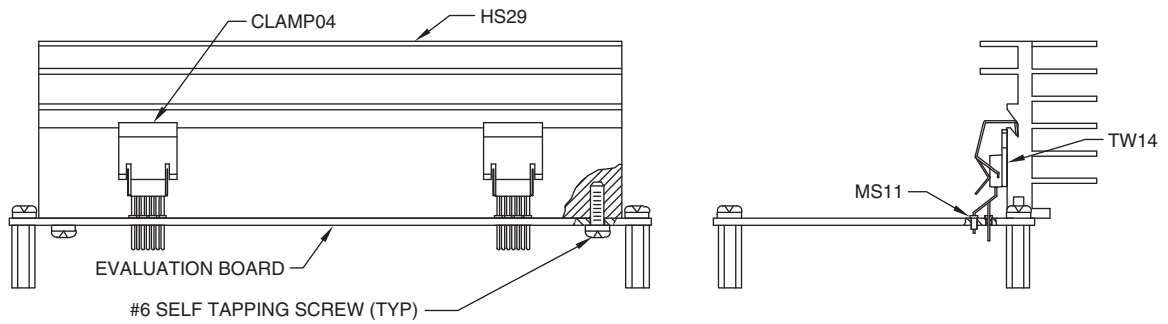

EVAL34
TOP

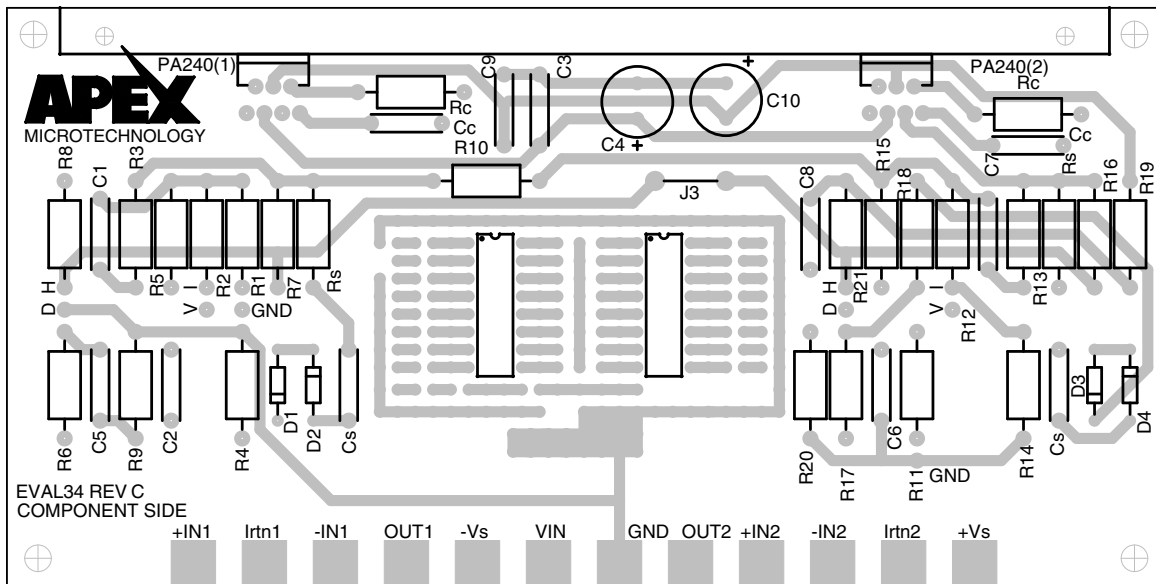

EVAL34
BOTTOM

